

# THEPROTECTOR Air Purifier-500

## Owner's Manual

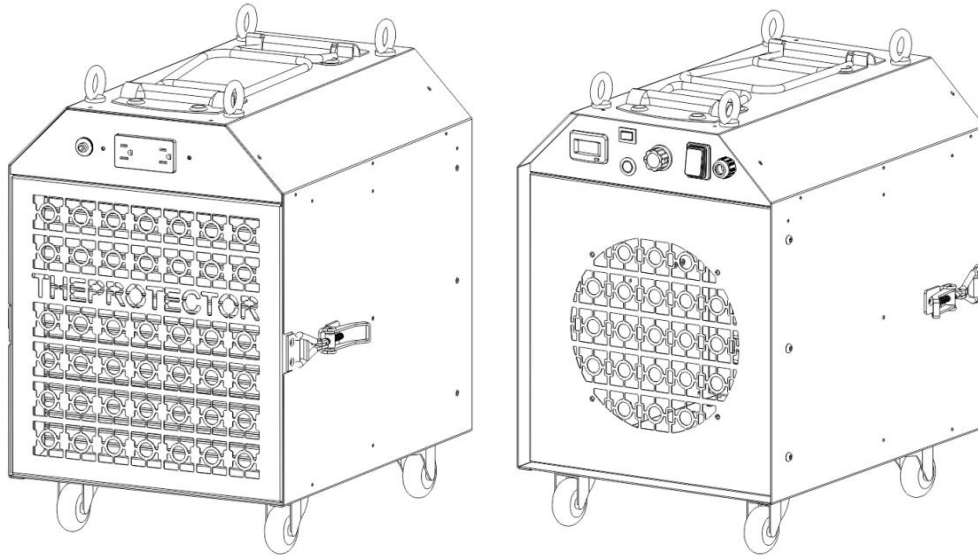

## READ AND SAVE THESE INSTRUCTIONS

### WARNING!

Please note that the air purifier should only be used with parts approved by supplier. The use of unauthorized parts or alterations to the machine could void your warranty. Contact an approved distributor for further assistance.

#### To Avoid the Risk of Fire or Electric Shock:

- Unit must be electrically grounded.
- Insert 3-prong plug directly into outlet with Ground Fault Circuit Interrupting device.
- Do not use an adapter with this unit.
- Do not use the unit in standing water.
- If electrical parts get wet, they must be dried prior to use.

## Precautions before use

1. Please make sure all filters packing bags removed before the machine plug in power supplier, otherwise it will cause risks or damage to the machine, like no filtering, machine does not work, etc.
2. The power supplier must be cutted off before replace any filters, all filters must use autherised or approved components, otherwise it will effect the filter effience or cause damage to the machine.

## INTRODUCTION

The air purifier is a convenient filtration system that cleans the air. The air purifier uses an effective blend of air flow and advanced filtration to expel airborne particles like mold spores, dust, pollen, and pet dander. The air purifier is ideal for for restoration jobs, including water, sewage, and fire.

## IDENTIFICATION

Congratulations on purchasing this air purifier . In order to take advantage of the warranty plan, be sure to note the serial number and date of purchase.

Serial Number: \_\_\_\_\_ Date of Purchase: \_\_\_\_\_

## HOW IT WORKS

When set to maximum airflow, purifier s pass through three types of filters -- pre-filters, H13 HEPA filters and activated carbon filters.

### 1. Pre-Filter

The first phase of filtration, the pre-filter, Captures initial dust and allergen particles.

### 2. Composite HEPA filter: include HEPA Filter (H13) and Activated Carbon Filter

**2.1 HEPA Filter (H13):**The third stage of filtration, the HEPA filter, captures even smaller particles, up to 0.3 microns.Helps control and prevent the growth of bacteria, bacteria and molds.Capturing 99.99% of dust and allergens.

**2.2 Activated Carbon Filter:**Multi-pore impregnated activated carbon can strongly adsorb VOC and remove formaldehyde. High-quality impregnated activated carbon has developed pore structure and can firmly adsorb formaldehyde, VOC and other gaseous pollutants. After the impregnation of the active solution, the active molecules in the carbon hole can gradually remove the absorbed part of formaldehyde.

### 3. UV-C Light

UV-C light technology works with filters to enhance the elimination of airborne germs Titanium Dioxide is activated by the UV-C light to decompose remaining odor molecules caused by smoking, cooking, and pets.

## SPECIAL FEATURES

### Daisy-Chain Capability

Using the auxiliary outlet on the control panel, you can link up to 3 units together. You can also daisy-chain the machines when they are stacked vertically (limit of 2 units).

### Multi-Positional

The air purifier can be operated in the vertical position, as well as, when stacked vertically (up to 2

units). When storing, the machines can be stacked horizontally to save space.

## KEY FEATURES

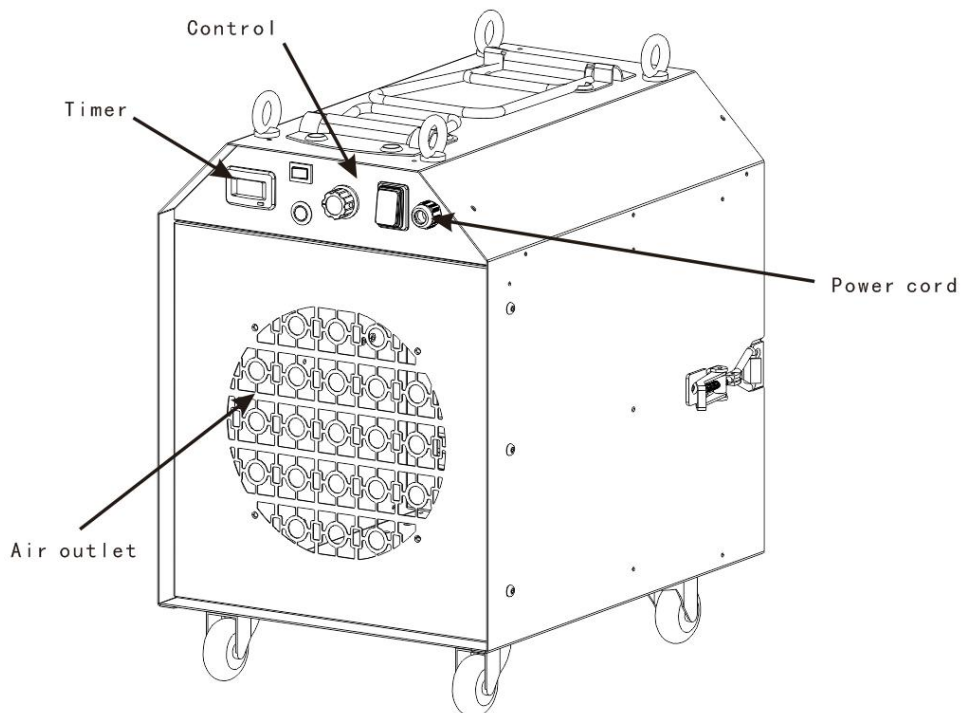
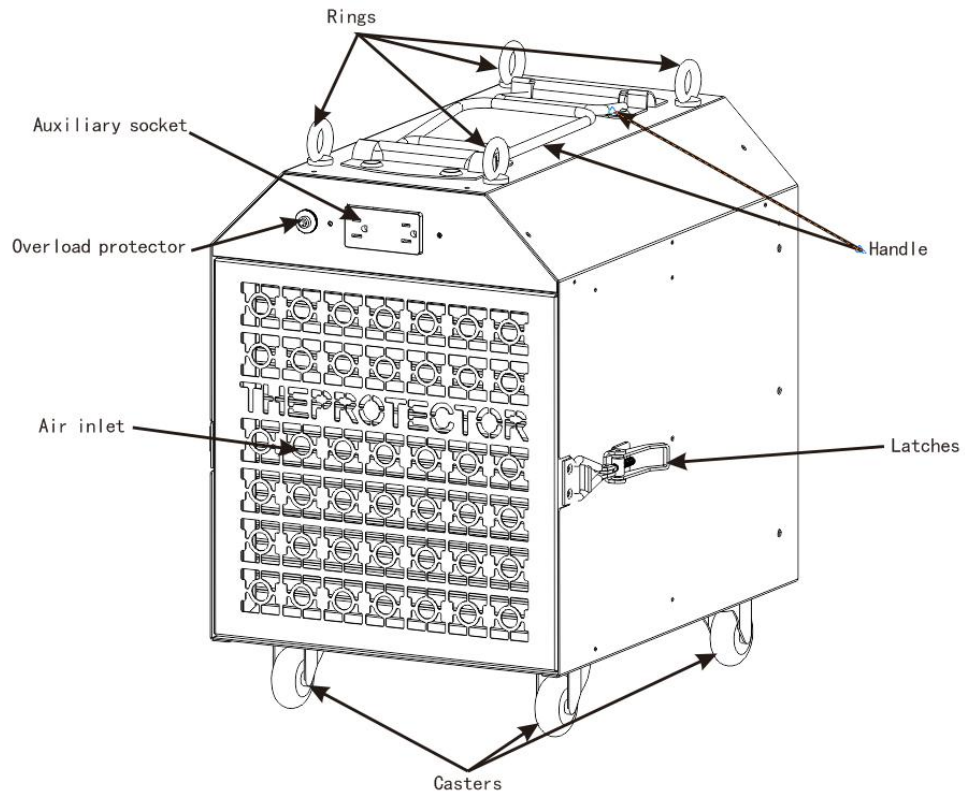

# INSTRUCTIONS

## SETUP

1. Place the air purifier so that it is in the upright, vertical position.
2. Plug the machine into a standard 120 volt outlet. *Note: Each unit needs 3.6amps to operate.*
3. Power the unit on and adjust the speed by turning the variable speed control. The maximum speed is 500 CFM.
4. The air purifier can be operated in the vertical or horizontal position, depending on the exact situation. At this point, adjust the machine to the optimal position.
5. When the machine total working time add up to 2000 hours, the filter replacement warning light on the control panel lights up to remind you to replace the filter. (To reset the machine, it had to push the UV-C light Switch 3 times continuously in 3 seconds after Reset the filter service time )
6. UV-C sterilization lamp fault detection function: when the UV-C sterilization lamp does not work, the buzzer will keep ringing.

## THE CONTROL PANEL

### Variable Speed Control

Variable speed control is used to adjust the power of the machine. Turn the knob in a clockwise direction, to increase the speed from minimum speed to maximum, the minimum speed setting is located immediately close to OFF.

### Auxiliary Outlet

If more air filtration is necessary for a space, you can "daisy chain" or link up to 3 air purifier to the same outlet. There is a maximum amperage of 12 when the units are turned off, a maximum of 8 amps when the units are turned on. Other equipment can be plugged into the same outlet as the air purifier as long as it doesn't go above the max amperage.

### Overload protector

If the current through the socket exceeds 15 Amps, the current protector will protect the device. If this happens, the current protector will cut off the power supply to the socket. The socket will not be energized until reset is pressed.

### Timer

Used to time the running time of the device. Start timing when the device is running, and pause timing when the device is stopped.

### Control function

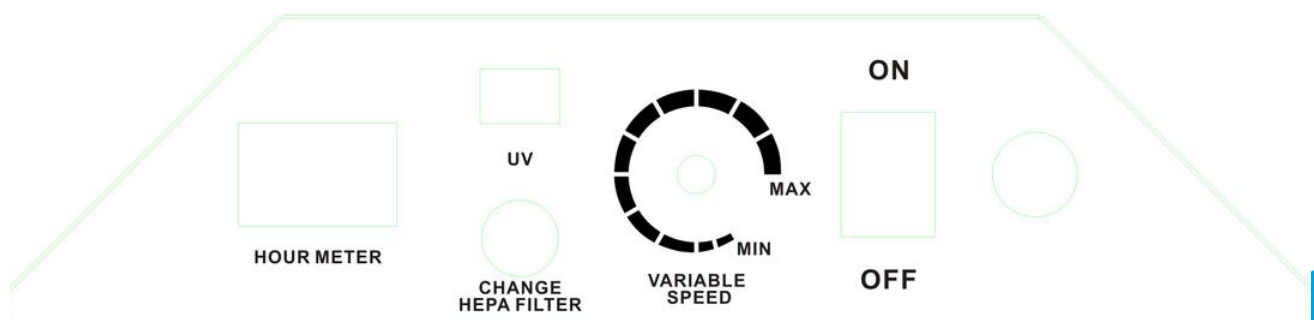

## CHANGING THE FILTERS

1. Loosen the 2 locks that hold the filter board in place.
2. Slide out the filter panel board.
3. Remove the used filters and replace with new filters.

### WARNING

- Always wear approved protective gear when changing the filters.
- Filters should be changed after each remediation job.
- If the indicator light is on, always change the HEPA/Activated Carbon Filter.

## APPLICATIONS

### Water Damage

In this application, the air purifier should be placed in the center of the affected area. The air purifier will draw in the air, filter it, then blow out the newly cleaned air. To begin the process, simply turn on the purifier and it will start cleaning the air. Keep in mind that if you are working in a large area or one divided by walls, you may need several air purifiers to effectively clean the air.

### Odor Control

The air purifier, when used with the HEPA/Activated Carbon Filter, is excellent at odor control, as well. Simply place the carbon filter in the pre-filter slot and it will capture a wide variety of odor-causing gas molecules, such as volatile organic compounds (VOC's), smoke, soot, and paint fumes.

### Other Uses

The air purifier is also useful in many other applications including mold remediation, fire damage, dust control, and sewage remediation.

## WARNING!

### Breathing Hazard

When using the air purifier in a containment area, always turn off power to open combustion appliances, such as fireplaces, furnaces, water heaters, and HVAC systems, to avoid the risk of back drafting carbon monoxide fumes.

If the Filter Change Light illuminates during the remediation process, immediately change the HEPA/Activated Carbon Filter.

### Tipping Hazard

- Use caution when stacking units.
- **The machine cannot be stacked**
- Falling equipment could cause bodily harm.

## WARNING!

WARNING: To reduce the risk of electric shock, do not expose to water or rain.

WARNING: NOT SUITABLE FOR USE WITH SOLID-STATE SPEED CONTROLS

CAUTION: To reduce the risk of electric shock, connect only to an outlet provided with a ground fault circuit interrupting device.

WARNING – Skin or eye damage may result from directly viewing the light

produced by the lamp in this apparatus. Always disconnect power before relamping or servicing. Replace Lamp With Lamp ZW4S15W-Z135, DC20V, 160mA 100-280nm.

## SAFETY NOTES

- Always unplug the unit prior to performing any maintenance.
- Check the power cord for damage (fraying, cuts, etc.) before use.
- To avoid electric shock, never use a water hose or pressure washer to clean the electrical components.
- Check the pre-filter prior to operating the machine to ensure it is not clogged. If there is any sign of airflow restriction change the filter.
- Make sure the unit is dry prior to installing clean filters.
- When using the air purifier for remediation purposes, replace both filters at the same time and always clean machine in between jobs. This will help prevent cross contamination.

## WARRANTY

All warranty benefits apply to the original owner only Warranty cannot be transferred or assigned.

**Customer Responsibilities:** In order to take advantage of the warranty service, the customer must do the following:

1. Customer must provide normal care and maintenance (including, but not limited to cleaning filters)
2. Removal and re-installation of unit is the sole responsibility of owner.
3. If customer cannot return unit to certified repair center, all costs associated with shipment are borne by the customer. In addition, all ancillary charges related to freight shipments, including but not limited to palletizing, wrapping, labeling, and pickup are associated with customer.
4. If shipped, customer is responsible for all risk of loss or damage.

## Warranty Exclusions:

DAMAGE DUE TO THE FOLLOWING IS NOT covered under warranty

1. Acts of Nature- including but not limited to:

Flooding

Fire

Water damage

Hurricane/storm

Damage

2. IMPROPER USAGE- Including but not limited to:

Misuse, abuse, or tampering whether intentional or accidental

Improper installation or design

Improper voltage

Lack of normal care

Failure to follow instructions

3. Corrosion
4. Freezing
5. Any additional costs due to changes in laws or building codes
6. Freight charges
7. Any costs due to lost profit or delay
8. Damage to property
9. Cause beyond control
10. Consumable parts, including but not limited to:
  - Filters
  - Batteries
  - Power cords
  - Valves
  - Switches
  - Rubber parts
11. Direct, indirect, collateral or inconsequential damages of any kind

## Wiring Diagram:



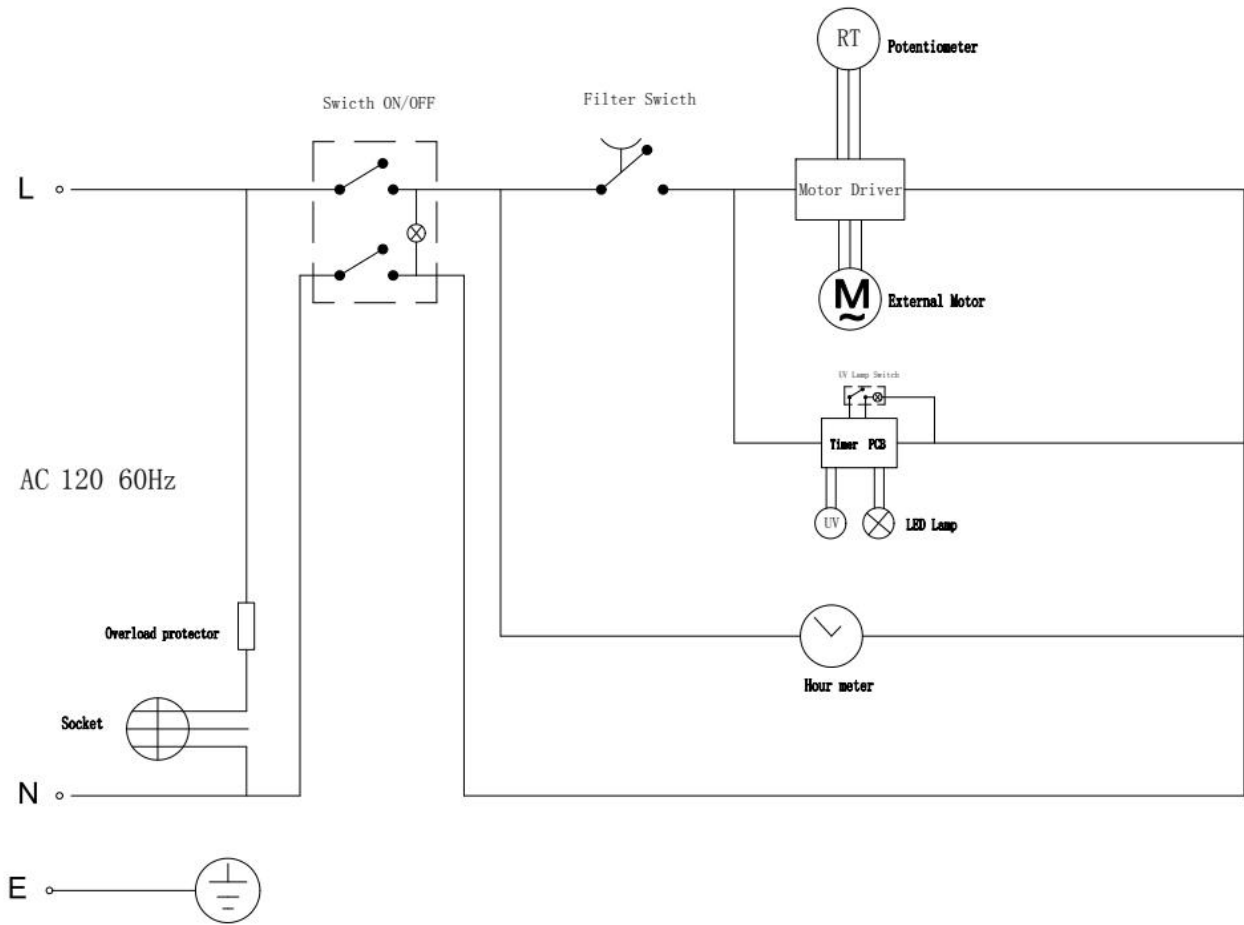





## THEPROTECTOR LIMITED PRODUCT WARRANTY

Please take the time to read through our Standard Terms and Conditions of the THEPROTECTOR Limited Product Warranty.

### How Long Does The Coverage Last?

This warranty applies only the device. Filters are excluded. The product warranty becomes effective from the date of purchase by the purchaser. Coverage terminates if you sell or otherwise transfer the product. The repair of your product under warranty will not extend the period of the warranty. Each part has its own warranty. Please check the warranty list before you place an order.

### How Do You Get Service?

Products are to be returned to THEPROTECTOR Tech Support Center under your express account. Address: 10725 Capital St. Oak Park. MI +1 248-542-1831

### What is Covered?

Normal wear and tear. We will repair or replace your product if your product is found, within the warranty period, to be defective due to defective materials or workmanship existing at the time of purchase. If any part is no longer available or out of manufacture, THEPROTECTOR will replace it with a functionally-equivalent replacement part.

### What is Not Covered?

THEPROTECTOR shall NOT be liable for costs of repair or replacement of a product incurred as a result of:

1. Accidental damage, faults caused by negligent use or care, neglect, careless operation or handling of the product which is not in accordance with the THEPROTECTOR Instruction Manuals.
2. Use of the parts not assembled or installed in accordance with the instructions of THEPROTECTOR.
3. Use of parts or accessories other than those produced or recommended by THEPROTECTOR.
4. External sources such as transit damage or weather.
5. Repairs or alterations carried out by parties other than THEPROTECTOR or its authorized agents.
6. Serial numbers defaced or missing.

THEPROTECTOR warrants the mechanical and electronic components of all THEPROTECTOR series to be free of defects in material and workmanship if used under normal operating conditions for a period from the original date of purchase. If the product shows any defects within this period and that defect is not due to user error or improper use THEPROTECTOR shall, at its discretion, either replace or repair the product using suitable new or refurbished parts. In case THEPROTECTOR decides to replace the entire product, this limited warranty shall apply to the replacement product for the remaining initial warranty period.

*THEPROTECTOR DISCLAIMS ANY AND ALL LIABILITY, INCLUDING ANY EXPRESS OR IMPLIED WARRANTIES, WHETHER ORAL OR WRITTEN, FOR SUCH THIRD PARTY HARDWARE. THE CUSTOMER ACKNOWLEDGES THAT THEPROTECTOR HAS MADE ITS BEST EFFORTS TO MATCH ITS PRODUCTS TO WORK WITH THIRD PARTY HARDWARE OR THE ABILITY TO CONNECT TO AND CONTROL THIRD PARTY HARDWARE FOR THE CUSTOMER'S INTENDED PURPOSE. THEPROTECTOR ADDITIONALLY AND SPECIFICALLY DISCLAIMS ANY AND ALL LIABILITY FOR CHANGES, ADDITIONS OR UPDATES IN ANY WAY TO A THIRD PARTY MANUFACTURES PRODUCTS.*

